

5. Instructions – cont'd

- 5.4. Using a 3/4" socket or wrench, run down the ram bolt until the tire bead has been pushed past the retaining lip on rim. Depending on the age of the tire and condition of the rim, the bead may partially return to the seated position. Make sure not to tighten the ram bolt past the point where the flange head contacts the tool body, which may result in stripping the threads out. Usually the bead will not become broken all the way around with one application of the BeadBuster, especially on the back side of the rim away from the drop center. *****CAUTION*** Do not allow fingers or body parts to get pinched between the bead and rim!**

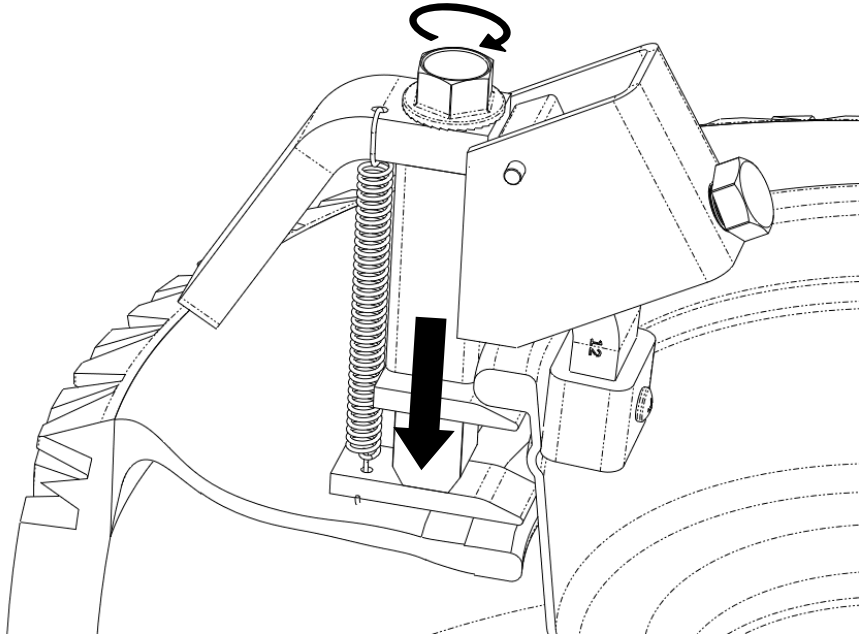

- 5.5. Loosen the ram bolt and clamp bolt. Move the BeadBuster to another location on the rim 2-3 inches from the first location. Tighten the clamp bolt and drive the ram bolt to break the bead. Repeat this process until the tire bead is completely loose from the rim.

BeadBuster
105 S. 12th St., Unit 500
Philadelphia, PA 19107
©2020 BeadBuster. All rights reserved.

www.BeadBuster.com
info@beadbuster.com
p. 215-948-2302



BeadBuster

XB-452

OWNERS MANUAL

v1.0

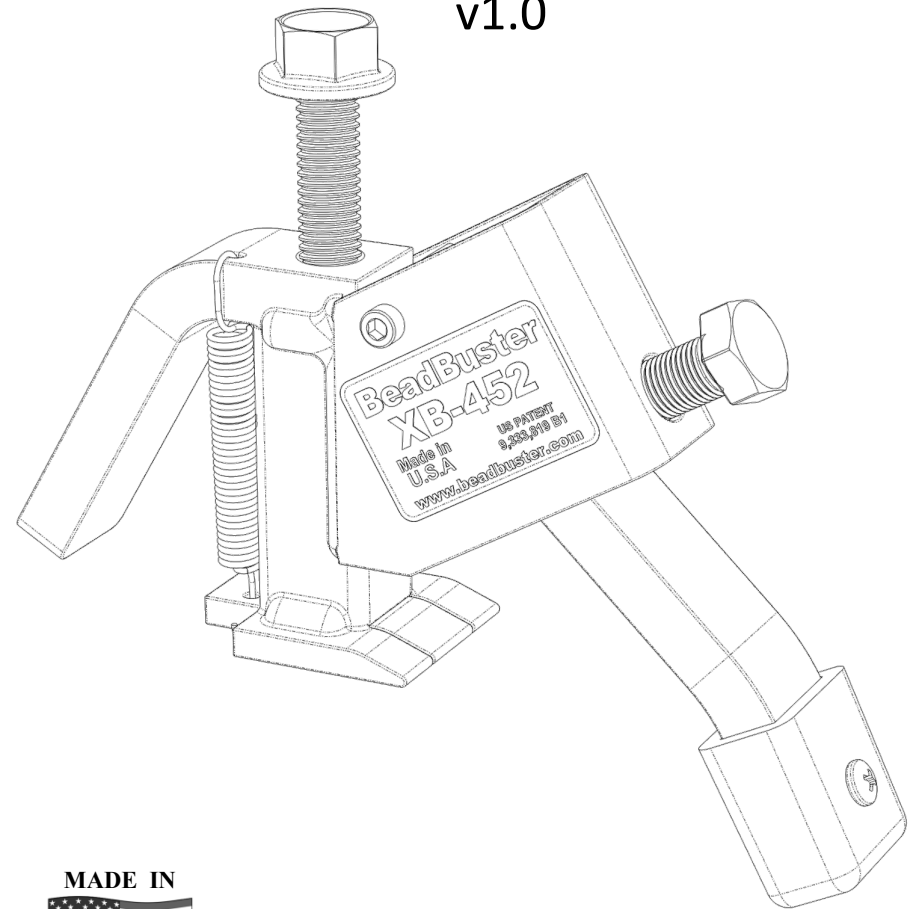

MADE IN

U. S. A.

PATENTED
US 9,333,819 B1

1. Overview

The **BeadBuster XB-452** is a small but powerful tool for breaking loose tire beads from rims. It is especially well suited for Automotive rims with contoured and angled features, but it works equally well on ATV's/UTV's, 4x4's, motorcycles, lawn equipment, and trailers. It does not require mounting and can be operated with hand tools. The BeadBuster applies a reaction force directly against the lip of the rim and won't bend lightweight aluminum rims from high compressive forces.

The XB-452 comes with a removable clamp hinge pin, so that the standard clamp arm can be exchanged. An extended length clamp arm is included for use with cast aluminum car and truck rims with contoured or angled surfaces that the standard clamp arm makes contact with. The long clamp arm reaches further down inside the rim where it is flatter allowing the clamp arm to make good contact to easily pull the feet in under the lip of the rim.

After breaking the bead on a rim, you will need tire irons to complete the job of removing the tire from the rim.

2. Safety

Keep fingers away from the clamp while tightening. Keep fingers out of the gap between the bead and rim.

3. Maintenance

Lubricate the threads on both bolts, and the ram shaft with light grease. This will keep the action smooth and reliable for years of use.

4. BeadBuster XB-452 Parts

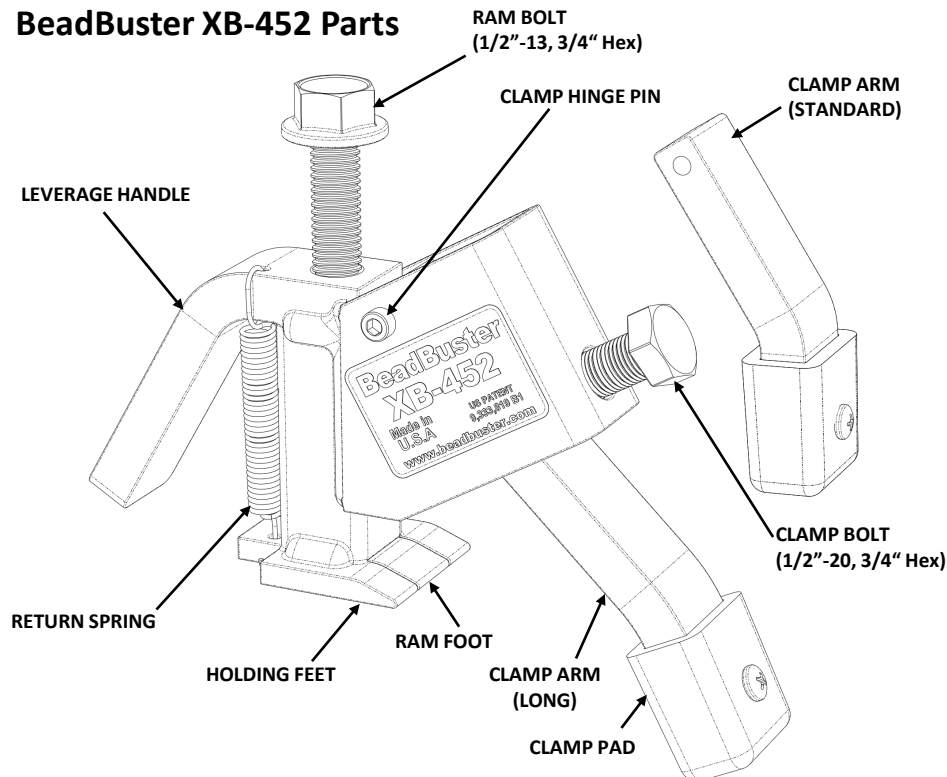

5. Instructions for breaking a bead

For more detailed instructions and videos, visit our website www.BeadBuster.com

- 5.1. Remove the valve core to release air pressure from the tire.
- 5.2. Press the BeadBuster feet in between the tire and rim. Use the sturdy 'Leverage Handle' to aid in getting the feet positioned. Lubricate the tire with soapy water to help let the feet slide in. Use the post-style clamp arm with reinforced rims, and feed the post through the holes in the reinforcing ring, as shown

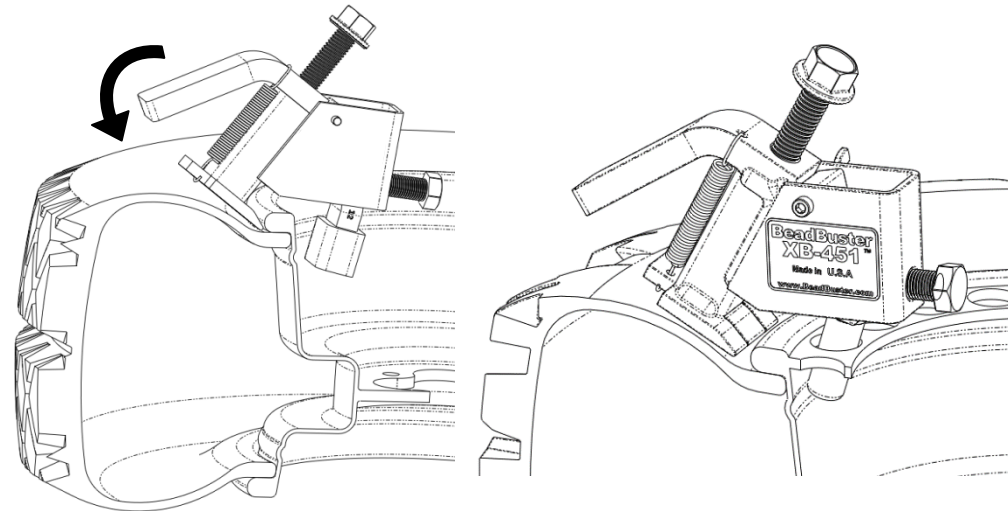

- 5.3. Using a 3/4" socket or wrench, tighten the clamp bolt on the BeadBuster using a small impact tool or hand wrench. Tighten the clamp bolt until the BeadBuster is vertical, and the body is touching the rim. Make sure the BeadBuster feet are fully inserted. Over-tightening the clamp will cause the tool to lean back and the ram foot to catch on the Bead Retainer of the rim! The Clamp Pad assures that the BeadBuster will not scratch your rims.

