

5. The BeadBuster XB-550 is equipped with a 2-sided Ram foot, as well as a magnetic spacer that, when combined, will accommodate a wide range of Wheel Sizes. Different wheels (ATV's vs. farm tractors vs. agricultural vs industrial, etc) all have different size wheel rim lip sizes, most critically is the lip depth. The function of the BeadBuster relies on the Ram Foot extending as far as possible underneath the lip of the rim so that it covers the steel cord (bead bundle), but does not go so far that it will engage the bead retainer when the rame foot pushes down. The 4 different combinations of ram foot side and spacer will work with a large range of rim lip depths.

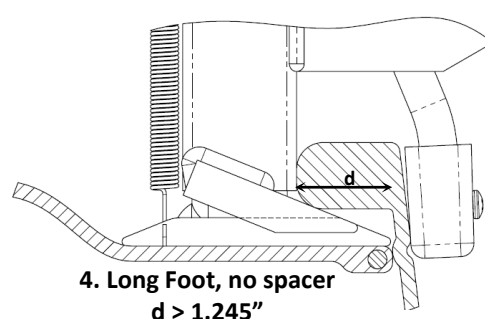
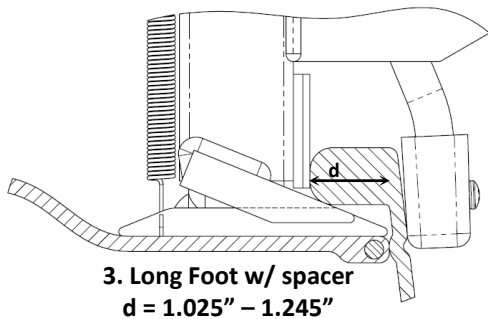
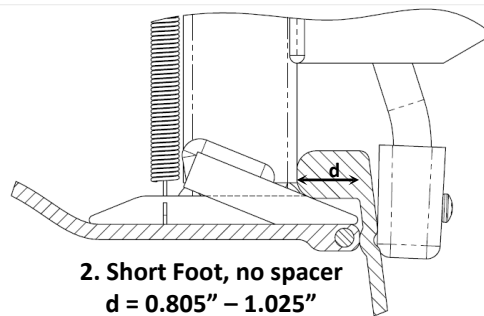
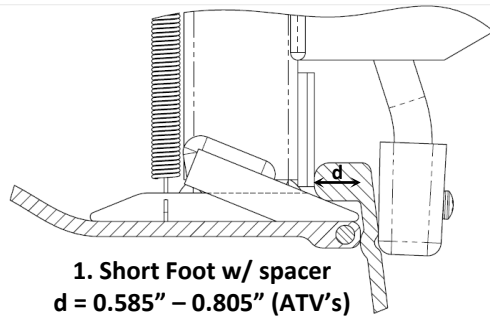
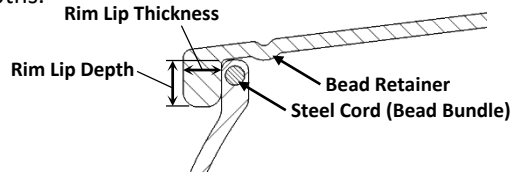

If you are unsure of your rim lip depth, you can approximate it by measuring the outermost diameter of the lip of the rim, and subtracting the inside diameter of the tire (standard tire diameter).

$$\text{Rim Lip Depth} = (\text{Outer Rim Dia.} - \text{Tire Dia.}) / 2$$

BeadBuster
105 S. 12th St., Unit 500
Philadelphia, PA 19107
©2020 BeadBuster. All rights reserved.

www.BeadBuster.com
info@beadbuster.com
p. 215-948-2302



BeadBuster™

XB-550

HEAVY DUTY OWNERS MANUAL

v1.3

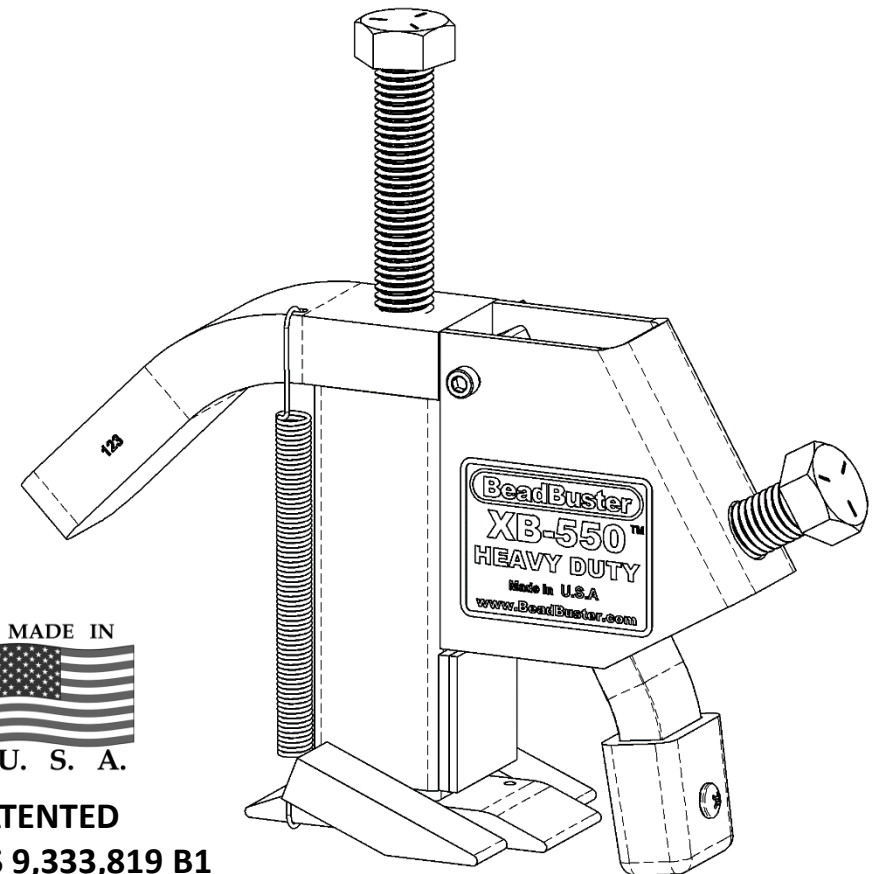

PATENTED
US 9,333,819 B1

BeadBuster XB-550 Parts

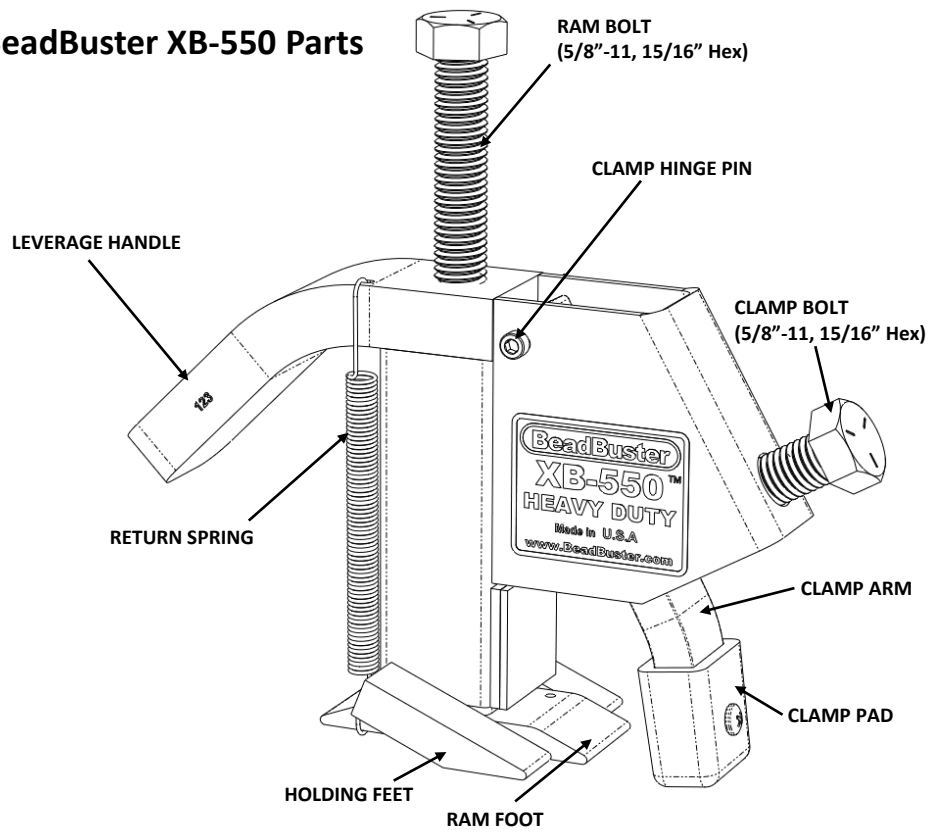

Instructions for breaking a bead

For more detailed instructions and videos, visit our website www.BeadBuster.com

1. Remove the valve core to release air pressure from the tire.
2. Press the BeadBuster feet in between the tire and rim. Use the sturdy 'Leverage Handle' to aid in getting the feet positioned. Lubricate the tire with soapy water to help let the feet slide in.

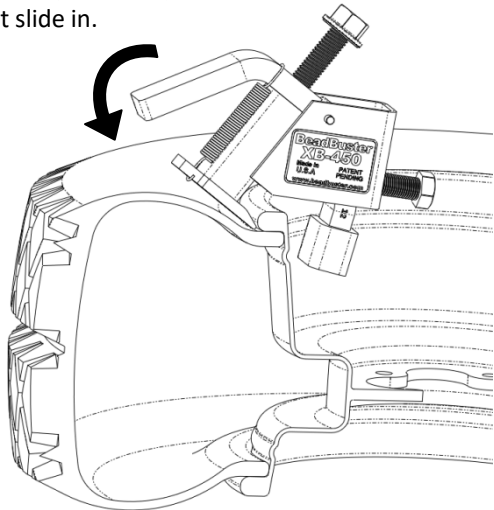

3. Using a 15/16" socket or wrench, tighten the clamp bolt on the BeadBuster using a small impact tool or hand wrench. Tighten the clamp bolt until the BeadBuster is vertical, and the body is touching the rim. Make sure the BeadBuster feet are fully inserted.

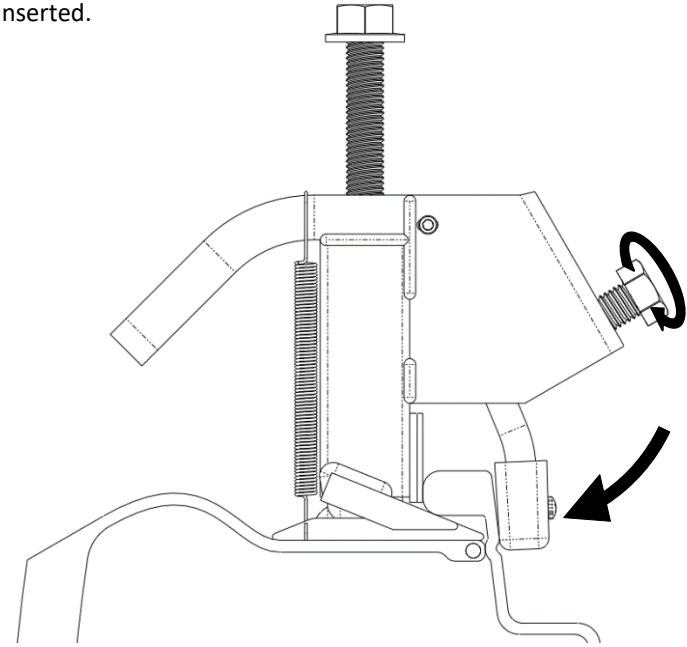

4. Using a 15/16" socket or wrench, run down the ram bolt until the tire bead has been pushed past the retaining lip on rim. Depending on the age of the tire and condition of the rim, the bead may partially return to the seated position. Make sure not to tighten the ram bolt past the point where the flange head contacts the tool body, which may result in stripping the threads out.

